



DynoRaxx[®] DynoGrip Evolution FR

Guide to Code Compliant Installation

Contents

I.	Installer Responsibilities	Page 3
II.	How to Use This Manual	Page 4
III.	Calculations	
	A. Wind Loads Worksheet	Page 5
	B. Load Forces Worksheet	Page 11
IV.	Installation Instructions	Page 18
V.	Appendices	
	A. Ground Snow Loads	Page 27
	B. Applied Variables	Page 30
	C. Applied Equations	Page 31
	D. DynoRaxx DYNAGRIP EVOLUTION FR System Orientation	Page 32
	E. DynoRaxx Limited Warranty	Page 33
	F. Standard Module Mounting Detail	Page 37

I. Installer Responsibilities

Thank you for choosing to install a photovoltaic system using the proprietary DynoRaxx DYNAGRIP EVOLUTION FR system. As installer, your job is important to ensuring that the photovoltaic system, of which the DynoRaxx DYNAGRIP EVOLUTION FR system is a component, is strong, durable and problem free for its expected life. As a result, the installer is primarily responsible for the quality of installation of any photovoltaic system that includes the DynoRaxx DYNAGRIP EVOLUTION FR system. We ask that you review this installation manual thoroughly before installing your DynoRaxx DYNAGRIP EVOLUTION FR system to ensure the photovoltaic system is installed correctly. The photovoltaic system must be installed in accordance with the instructions in the owners manual including wind and load forces calculation to meet the requirements of the ASCE 7-05 and IBC 2006 code. DynoRaxx also provides a limited warranty on the DynoRaxx DYNAGRIP EVOLUTION FR system if installed according to the installation manual. By choosing the DynoRaxx DYNAGRIP EVOLUTION FR system, you get more than just a robust, high-quality, racking system designed to outlast the photovoltaic panels themselves, you have our support through the planning and installation process to resolve any technical issue that you encounter.

It is the installer's sole responsibility to do the following and failure to do so may void the limited manufacturer warranty on the DynoRaxx DYNAGRIP EVOLUTION FR system:

- Determine whether the DynoRaxx DYNAGRIP EVOLUTION FR system is appropriate for a particular application or location.
- Determine whether the building structure including the roof, its rafters and other structural supports can support the entire photovoltaic system under all code loading conditions including the weight of ballasts required to meet any applicable building codes.
- Use a qualified professional to design the photovoltaic system applying all appropriate design parameters to determine that loading meets or exceeds the requirements of this manual and all applicable codes including but not limited to snow loading, wind speed, exposure, and topographic factors.
- Know and comply with all applicable building codes both local and national, including codes that may have additional requirements that are not found in this manual.
- Obtain all required building permits and approvals.
- Make sure that the DynoRaxx DYNAGRIP EVOLUTION FR system is adequately ballasted according to the guidelines in this installation manual and any applicable building code.
- Make sure that the installation of the photovoltaic system using DynoRaxx DYNAGRIP EVOLUTION FR system is on a roof that is in good condition, has a sound water barrier including waterproof membrane that does not leak and is reasonably expected to have an effective life that is equal to or longer than the expected life of the photovoltaic system including the DynoRaxx DYNAGRIP EVOLUTION FR system.
- Use only DynoRaxx supplied specified or approved parts.
- Make sure that no parts are installed that are visibly damaged including parts that have coating removed by scratching, corrosive materials or environment.
- Install the electrical system of the photovoltaic system safely and meets or exceeds all electrical code requirements.

II. How To Use This Manual

This manual is intended for installer use in assessing the feasibility of the DynoRaxx DYNAGRIP EVOLUTION FR system on a given site. By completing these calculations the customer will be provided with:

- The forces due to wind loading
- The number of DYNAGRIP EVOLUTION FR components your project requires
- The amount of ballast blocks your project requires

Worksheets

The worksheets are intended to be used as a reference tool for proper completion of the manual. It is recommended that they are torn out and filled in as each step is completed. This will prevent confusion in later steps. Whenever a box is referenced, the instructions are referring to a numbered box on the Wind Loads Worksheet and the Load Forces Worksheet.

Figures and Tables

Most figures and tables in this manual are referenced from ASCE 7-05. Many are partial representations designed to meet the needs of the majority of customers. If your firm is using the DynoRaxx DYNAGRIP EVOLUTION FR on a continuous basis in areas that are not well represented by the figures in this manual it is recommended that you purchase the ASCE 7-05 manual or consult a professional engineer.

Appendices

The appendices provide in depth references to be used in conjunction with this manual. If details seem unclear within the context of the manual it is highly recommended to consult the appendices first.

III. Calculations

A. Wind Loads Worksheet

a. Roof height h	a.	ft.
b. Building width w	b.	ft.
1. Basic windspeed V	1.	mph
2. Roof endzone length a	2.	ft.
3. Topographic factor K_{zt}	3.	1
4. Exposure Category (B,C,D)	4.	
5. Velocity pressure exposure coefficient K_z	5.	
6. Wind directionality factor K_d	6.	.85
7. Structure Classification (I, II, III, IV)	7.	
8. Importance factor I	8.	
9. Velocity pressure due to wind q_h	9.	
10. Gust factor G	10.	.85
11. Net pressure coefficients		
11a. C_{nc}	11a.	1.28
11b. C_{nd}	11b.	-.9
12. Wind loads		
12a. Compressive design wind load p_c	12a.	psf
12b. Tensile design wind load p_T	12b.	psf

Task 1: Determine the site’s basic wind speed V (mph) using Figure 1. For most areas of the United States use 90 mph. Use 85 mph for the West Coast and the nearest line value for areas along the East and Gulf Coast. Consult a professional for special wind regions and territories other than those represented on this map.

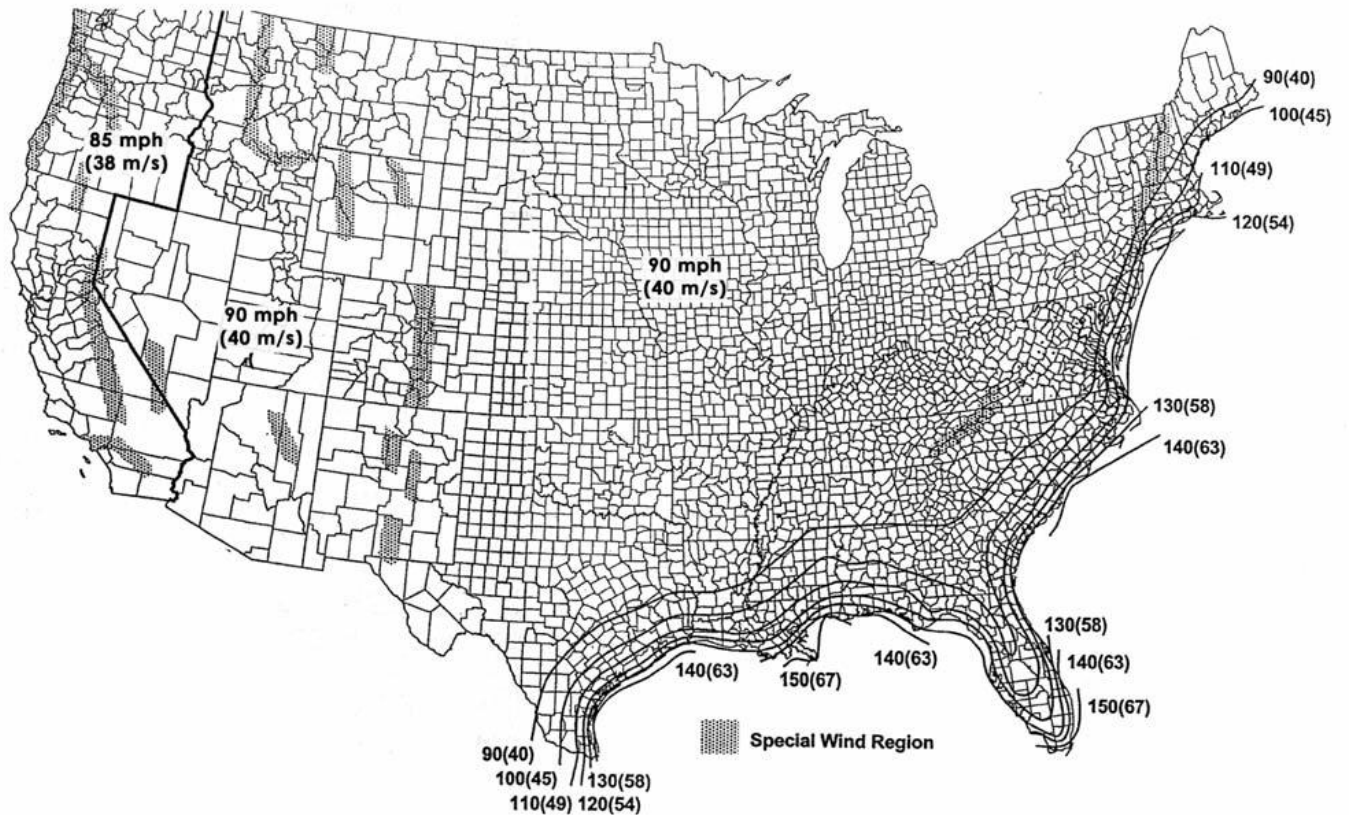

Figure 1: Basic Windspeed (ASCE 7-05 figure 6-1 p. 33)

*Values are nominal design 3-second gust wind speeds in miles per hour (m/s) at 33 ft (10 m) above ground for Exposure C category.

Task 2: The building roof endzone length a (ft) is equal to 10% of the building width w (Box b, page 5) or its height (Box a, page 5) multiplied by .4, whichever is smaller. However, if the smaller of the two values is less than 4% of the building width or 3 ft, use the larger of these latter criteria.

The building zone must be determined using Figure 2. If any portion of the system will be located in zones 2 and / or 3, please consult a professional engineer.

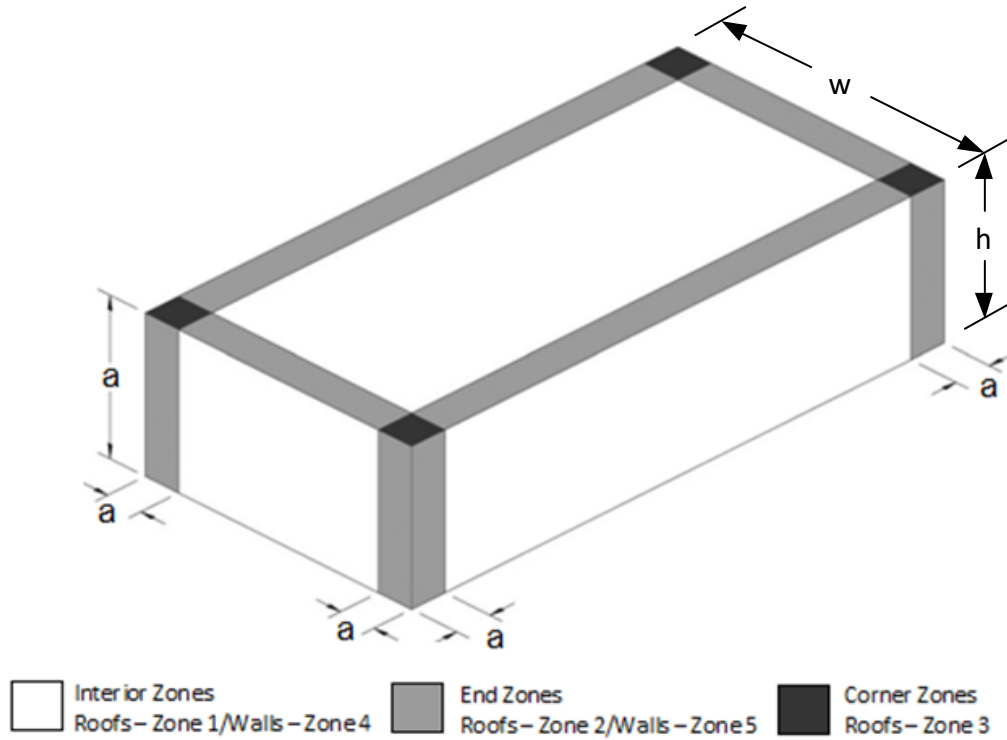

Figure 2: Flat Roof Building Zones (ASCE 7-05 Figure 6-3 p. 41)

Task 3: The topographic factor K_{zt} is equal to **1** for roof slopes less than 10% (ASCE 7-05)

Task 4: The DynoRaxx DYNAGRIP EVOLUTION FR System is designed for use in exposure categories B,C, and D. Determine the site exposure category using the following descriptions from ASCE 7-05 p. 286-291. Please confirm the site description with the local building authority.

- Exposure B
- Suburban residential areas with mostly single-family dwellings
 - Low-rise structures, less than 30 feet high
 - Urban areas with numerous closely spaced obstructions having size of single family dwellings or larger

- Exposure C
- Flat open grassland with scattered obstructions having heights generally less than 30 feet
 - Open terrain with scattered obstructions having heights generally less than 30 feet for most wind directions
 - Structures are all less than 1500 feet or 10 times their height, whichever is greater, from an open field that prevents the use of exposure B

- Exposure D
- A building at the shoreline (excluding shorelines in hurricane-prone regions) with wind flowing over open water for a distance of at least 1 mile
 - Shorelines in exposure D include inland waterways, the Great Lakes, and coastal areas of California, Oregon, Washington, and Alaska

Task 5: Determine the velocity pressure exposure coefficient K_z using the roof height (Box a, Page 5), exposure category (Box 4, Page 5), and Table 1.

Table 1: Velocity pressure coefficient K_z (ASCE 7-05 Figure 6-3 p. 40)

Roof Height h (ft.)	Exposure Category		
	B	C	D
0-15	.70	.85	1.03
20	.70	.90	1.08
25	.70	.94	1.12
30	.70	.98	1.16
40	.76	1.04	1.22
50	.81	1.09	1.27
60	.85	1.13	1.31
70	.89	1.17	1.34
80	.93	1.21	1.38
90	.96	1.24	1.40
100	.99	1.26	1.43

Task 6: The wind directionality factor K_d is **.85** for building components and cladding.

(ASCE 7-05 Table 6-4 p. 80)

Task 7: Determine the structure classification category using Table 2.

Table 2: Structure Classification

Occupancy Category	Nature of Occupancy
I	Buildings and other structures that represent a low hazard to human life in the event of failure, including but not limited to: <ul style="list-style-type: none"> • Agricultural Facilities • Certain temporary facilities • Minor storage facilities
II	Buildings and other structures except those listed in Categories I, III, and IV
III	Structures that represent a substantial hazard to human life in the event of failure including, but not limited to: <ul style="list-style-type: none"> • Buildings where more than 300 people congregate in one area • Buildings with day-care facilities with capacity greater than 150 • Buildings with elementary or secondary schools with capacity greater than 250 • Buildings with an occupant load greater than 500 for colleges or adult education facilities • Health care facilities with an occupant load of 50 or more resident patients, but not having surgery or emergency treatment facilities • Jails and detention facilities • Any other building with an occupant load greater than 5,000 • Power-generating stations, water treatment for potable water, waste water treatment facilities and other public utility facilities not included in Occupancy Category IV
IV	Building and other structures designated as essential facilities, including but not limited to: <ul style="list-style-type: none"> • Hospitals and other health care facilities having surgery or emergency treatment facilities • Fire, rescue, and police stations and emergency vehicle garages • Designated earthquake, hurricane or other emergency shelters • Designated emergency preparedness, communication, and operation centers and other facilities required for emergency response. • Power-generating stations and other public utility facilities required as emergency backup facilities for Occupancy Category IV Structures • Ancillary structures (including, but not limited to, communication towers, fuel storage tanks, cooling towers, electrical substation structures, fire water storage tanks, or other structures housing or supporting water, or emergency • Aviation control towers, air traffic control centers, and emergency aircraft hangars • Water storage facilities and pump structures required to maintain water pressure for fire suppression • Buildings and other structures having critical national defense functions

*Adapted from ASCE 7-05 Table 1-1

Task 8: The DynoRaxx DYNAGRIP EVOLUTION FR System is not recommended for hurricane prone regions. Determine the importance factor I using the structure classification (Box 7, Page 5) and Table 3.

Table 3: Importance Factor I (Wind Loads)

Category	Importance Factor
I	.87
II	1.00
III	1.15
IV	1.15

*Adapted from ASCE 7-05 Table 6-1 p.77

Task 9: Calculate the velocity pressure due to wind q_h by using the velocity pressure coefficient K_z (Box 5, Page 5), the topographic factor K_{zt} (Box 3, Page 5), the basic velocity V (Box 1, Page 5), the importance factor I (Box 8, Page 5) and Equation 1.

$$q_H = .00256K_zK_{zt}V^2I \quad (\text{Equation 1})$$

Task 10: The gust-effect factor G is equal to **.85** for rigid structures (ASCE 7-05 section 6.5.8 p. 26)

Task 11: The average net pressure coefficients for a photovoltaic panel at a 10 degree angle attack are as follows (ASCE 7-05, Figure 6-18A, p. 66).

$$C_{nC} = 1.28$$

$$C_{nT} = -.9$$

Task 12: Calculate the compressive wind load p_c and tensile wind load p_t using the velocity pressure q_H (Box 9, Page 5), the gust factor G (Box 10, Page 5), the net pressure coefficients C_{nC} and C_{nT} (Boxes 10a and 10b, Page 5), and Equations 2 and 3.

$$p_C = q_hGC_{nC} \quad (\text{Equation 2})$$

$$p_T = q_hGC_{nT} \quad (\text{Equation 3})$$

The design wind loads p_c and p_T will be used in section III to calculate the load forces for the DynoRaxx DYNAGRIP EVOLUTION FR System.

B. Load Forces Worksheet

a. Total number of modules in array n_m	a.	
b. Module length l_m	b.	in.
c. Module width w_m	c.	in.
d. Module area $A_m (l_m w_m \frac{1ft.^2}{144in.^2})$	d.	ft. ²
e. Module weight F_m	e.	lbs.
f. Width of basket w_{bk}	f.	23.291 in.
g. Weight of two leg basket F_2	g.	4.7 lbs.
h. Weight of four leg basket F_4	h.	7 lbs.
i. Weight of one DynoGrip set F_0	i.	.694 lbs.
1. Design wind load force per unit module		
1a. Tensile wind load force W_T	1a.	lbs.
1b. Compressive wind load force W_C	1b.	lbs.
2. YZ components of tensile wind load force per unit module		
2a. Y component W_{Ty}	2a.	lbs.
2b. Z component W_{Tz}	2b.	lbs.
3. YZ components of compressive wind load force per unit module		
3a. Y component W_{Cy}	3a.	lbs.
3b. Z component W_{Cz}	3b.	lbs.
4. Ground snow load p_s	4.	psf.

5. Snow load force per unit module S_m	5.	lbs.
6. Racking variables		
6a. Number of modules with an open South edge n_{mS}	6a.	
6b. Number of rows with an open South edge n_{rS}	6b.	
6c. Number of modules with an open West edge n_{mW}	6c.	
6d. Number of inside array corners n_c	6d.	
7. Racking materials		
7a. Number of two leg baskets n_2	7a.	
7b. Number of four leg baskets n_4	7b.	
7c. Number of rail sets n_0	7c.	
8. Total array area A_{tot}	8.	ft.²
9. Total array weight F_{tot}	9.	lbs.
10. Dead load force per unit module D_m	10.	lbs.
11. Nominal load combinations		
11a. Load sum 1 Sum_1	11a.	lbs.
11b. Load sum 2 Sum_2	11b.	lbs.
11c. Load sum 3 Sum_3	11c.	lbs.
11d. Load sum 4 Sum_4	11d.	lbs.
12. Z direction load force combinations		
12a. Positive z component F_{z+}	12a.	lbs.
12b. Negative z component F_{z-}	12b.	lbs.
13. Y direction load force combinations		
13a. Positive y component F_{y+}	13a.	lbs.



13b. Negative y component F_{y-}	13b.	lbs.
14. Roof surface coefficient of friction μ	14.	.4
15. Force due to friction F_{fr}	15.	lbs.
16. Ballast requirement to overcome drag B_{drag}	16.	lbs.
17. Code calculated module ballast weight requirement B_c	17.	lbs.
18. True ballast requirement B_{true}	18.	lbs.
19. Number of ballast blocks required per module n_{blocks}	19.	

Task 1: Calculate the wind load forces W_T and W_C (lbs) using the wind loads p_T and p_C (Box 12, Page 5), the module area A_m , and Equations 4 and 5.

$$W_T = p_T A_m \quad \text{(Equation 4)}$$

$$W_C = p_C A_m \quad \text{(Equation 5)}$$

Task 2: Calculate the y and z components of the tensile wind load force W_{Ty} and W_{Tz} (lbs) using the tensile wind load force W_T (Box 1a, Page 11) and Equations 6 and 7.

$$W_{Ty} = W_T \sin (10) \quad \text{(Equation 6)}$$

$$W_{Tz} = W_T \cos (10) \quad \text{(Equation 7)}$$

Task 3: Calculate the y and z components of the compressive wind load force W_{Cy} and W_{Cz} (lbs) using the compressive wind load force W_C (Box 1b, Page 11) and Equations 8 and 9.

$$W_{Cy} = W_C \sin (10) \quad \text{(Equation 8)}$$

$$W_{Cz} = W_C \cos (10) \quad \text{(Equation 9)}$$

Task 4: Determine the ground snow load p_s (psf) using Appendix A. If the site is located in a site marked case study (CS). Consult the building architect or an equivalent professional.

Task 5: Calculate the ground snow load force per unit module S_m (lbs) using the ground snow load p_s (Box 4, Page 11), the module area A_m (Box d, Page 11), and Equation 10.

$$S_m = (.7)p_s A_m \cos (10) \quad \text{(Equation 10)}$$

Task 6: The racking factors are used to determine how many two and four leg DynoRaxx DYNAGRIP EVOLUTION FR System baskets are required for this array. Use the following descriptions for Boxes 6a-6d.

- a. Modules with an open South edge n_{mS} are not connected to another module by their southern edge. These occur at south facing building edges and at the northern edge of roof obstacles.
- b. Rows with an open South edge n_{rS} are classified as any row containing one or more modules with an open South edge.
- c. Modules with an open West edge n_{mW} are not connected to another module by their western edge. These occur at West facing building edges and at the eastern edge of roof obstacles.
- d. The number of inside corners n_c include all corners at inside bends to the array. Do not include outward bending corners.

Task 7: The number of two legged baskets n_2 , four legged baskets n_4 , and rail sets n_0 can be calculated using the number of modules with an open South edge n_{mS} (Box 6a, Page 12), rows with an open South edge n_{rS} (Box 6b, Page 12), corners n_c (Box 6d, Page 12), modules with an open West edge n_{mW} (Box 6c, Page 12), the total number of modules (Box a, Page 11), and Equations 11 through 13.

$$n_2 = n_{mS} + n_{rS} + n_c \quad \text{(Equation 11)}$$

$$n_4 = n_m + n_{mW} \quad \text{(Equation 12)}$$

$$n_0 = n_m \quad \text{(Equation 13)}$$

Task 8: The total array area A_{tot} (ft²) includes all modules and racking materials. It is calculated using the module width w_m (Box c, Page 11), the number of modules with an open South edge n_{mS} (Box 6b, Page 12), the number of modules n_m (Box a, Page 11), the module length l_m (Box b, Page 11), the basket width w_b (Box f, Page 11), and Equation 14.

$$A_{tot} = \frac{l_m}{144} [n_{mS}w_m \cos(10) + (n_m - n_{mS})(w_m \cos(10) + w_{bk})] \quad \text{(Equation 14)}$$

Task 9: The total array weight F_{tot} (lbs) includes all modules and racking materials. It is calculated using the module weight F_m (Box e, Page 11), the number of modules n_m (Box a, Page 11), the two legged basket weight F_2 (Box g, Page 11), the number of two legged baskets n_2 (Box 7a, Page 12), the four legged basket weight F_4 (Box h, Page 12), the number of four legged baskets n_4 (Box 7b, Page 12), the rail set weight F_0 (Box i, Page 11), the number of rail sets n_0 (Box 7c, Page 12), and Equation 15.

$$F_{tot} = F_m n_m + F_2 n_2 + F_4 n_4 + F_0 n_0 \quad \text{(Equation 15)}$$

Task 10: The dead load force per unit module D_m is the weight realized by the roof per module before adding ballast. It is calculated using the total array weight F_{tot} , the number of modules n_m , and Equation 16.

$$D_m = \frac{F_{tot}}{n_m} \quad \text{(Equation 16)}$$

Task 11: The nominal load summations represent all load combinations present on the array at one time. They are as specified in ASCE 7-05 section 2.4.1 p. 5.

$$Sum_1 = D_m + S_m \quad \text{(Equation 17)}$$

$$Sum_2 = D_m + W_{Cz} \quad \text{(Equation 18)}$$

$$Sum_3 = D_m + .75(S_m + W_{Cz}) \quad \text{(Equation 19)}$$

$$Sum_4 = .6D_m + W_{Tz} \quad \text{(Equation 20)}$$

Task 12: The design load force in the positive z direction F_{z+} is equal to the greatest of Sum_1 , Sum_2 , and Sum_3 , while the load force in the negative z direction F_{z-} is equal to Sum_4 .

Task 13: The design load force in the positive y direction F_{y+} is equal to W_{Cy} (Box 3a, Page 12) and the design load force in the negative y direction F_{y-} is equal to W_{Ty} (Box 2a, Page 12).

**The loads in boxes 12 and 13 are distributed over four DynoPins, each with an allowable shear tolerance of 830 lbs. The combined shear forces on these pins must not exceed this allowable value. To determine whether the load forces meet this criterion, use the maximum force in the z direction (Box 12a or 12b, Page 12) and the maximum force in the y direction (Box 13a or 13b, Page 12).

$$\frac{1}{4} \sqrt{F_{zmax}^2 + F_{ymax}^2} < 830 \quad \text{(Equation 21)}$$

Task 14: DynoRaxx used an average coefficient of friction μ of .4. Slight inaccuracies are accounted for within applied safety factors. If the site roof was constructed using non-conventional means please contact a professional engineer to determine whether this average value applies.

Task 15: The force due to friction F_{fr} (lbs) is calculated using the roof surface coefficient of friction μ (box 14) the dead load force per module D_m (box 10), and Equation 22. The dead load force per module is multiplied by a factor of .6 in accordance to the basic load combinations in ASCE 7-05 section 2.4 page 5.

$$F_{fr} = .6D_m\mu \quad \text{(Equation 22)}$$

Task 16: If the y component of the tensile wind force W_{Ty} (Box 2a, Page 11) is greater than the force due to friction F_{fr} (Box 15, Page 13) that the required ballast to overcome drag B_{drag} (lbs) is determined using equation 23. Otherwise, B_{drag} is equal to zero.

$$B_{drag} = \frac{1}{.4} (|W_{Ty}| - F_{fr}) \quad \text{(Equation 23)}$$

Task 17: The code compliant ballast requirement per module B_c (lbs) is equal to the sum of the ballast required to overcome drag B_{drag} (Box 16, Page 13) and the absolute value of the combined load forces in the negative Z direction F_{z-} (Box 12b, Page 12).

$$B_c = B_{drag} + |F_{z-}| \quad \text{(Equation 24)}$$

Task 18: The true ballast requirement B_{true} (lbs) is an adjustment to the code compliant ballast requirement based off of extensive wind tunnel testing. The experimentally determined wind tunnel adjustment factor is equal to .473. A safety factor of 1.15 is also required for the system.

$$B_{true} = (.473)1.15B_c \quad \text{(Equation 25)}$$

Task 19: The number of ballast blocks required per module n_b is calculated using the true ballast requirement B_{true} (Box 18, Page 13) and equation 26. These calculations are based on cap blocks 4"x8"x16" in size and 34 lbs. in weight.

$$n_b = \frac{B_{true}}{34} \quad \text{(Equation 26)}$$

Installation Instructions

Site plans are often completed assuming perfectly flat rooftops and geometrically symmetric arrays. In the field this is rarely the case. The DYNOG RIP EVOLUTION FR system’s modular design allows for versatile design and installation. Please follow these installation guidelines to ensure an efficient and code compliant installation.

DynoRaxx DynoGrip Evolution FR Components:



Two Leg Basket

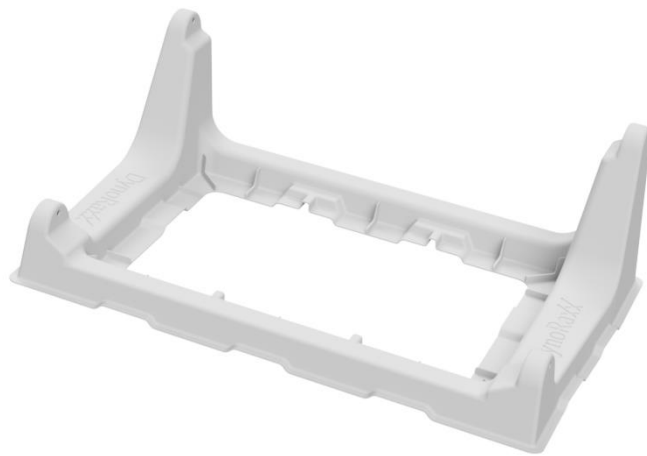

Four Leg Basket



DynoGrip



DynoPin or Equal

Step 1: Begin installation by snapping a chalk line to square and center the system. Properly align this square within the building zones and dimensions allotted by the design engineer.

Step 2: Place a two leg basket with the legs facing South in the Southeast corner of the chalk line. It's imperative that extra care is taken to make sure this basket is oriented correctly since any imperfections will be magnified exponentially as you move further through the installation. For large systems, starting from the center of the system and working east and west will limit the effect of inaccurate measurements.

Step 3: Place a four leg basket approximately one and a half (1.5) feet north of the two leg basket oriented with the tall legs facing south. Place a second set of baskets approximately two (2) feet from the western edge of the first pair of baskets. This distance will vary depending on the dimensions of the solar panels being installed.

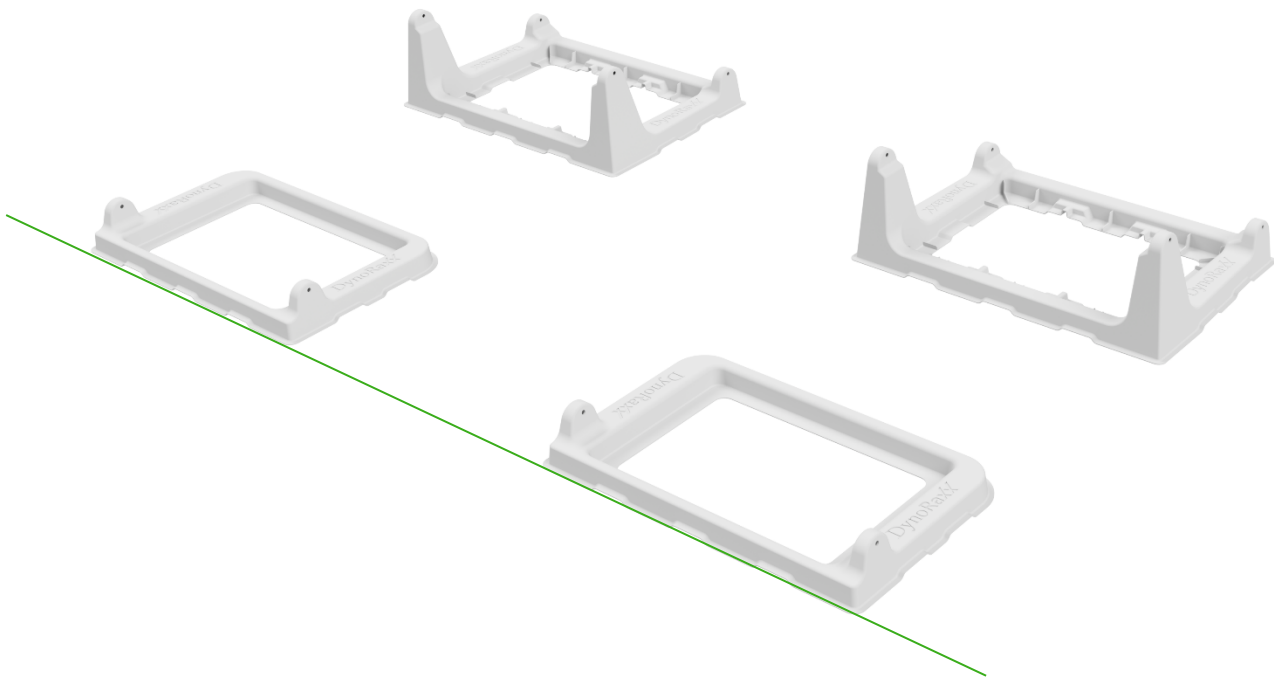

Step 4: While solar panels are on the pallet, using a T-Square mark the panel fourteen (14") inches in from the short side at four locations along the long sides of the panel. This line will serve as the setting point for the DynoGrip. Refer to Appendix F for more details. **ONLY INSTALL 4 DYNOGRIPS PER PANEL**

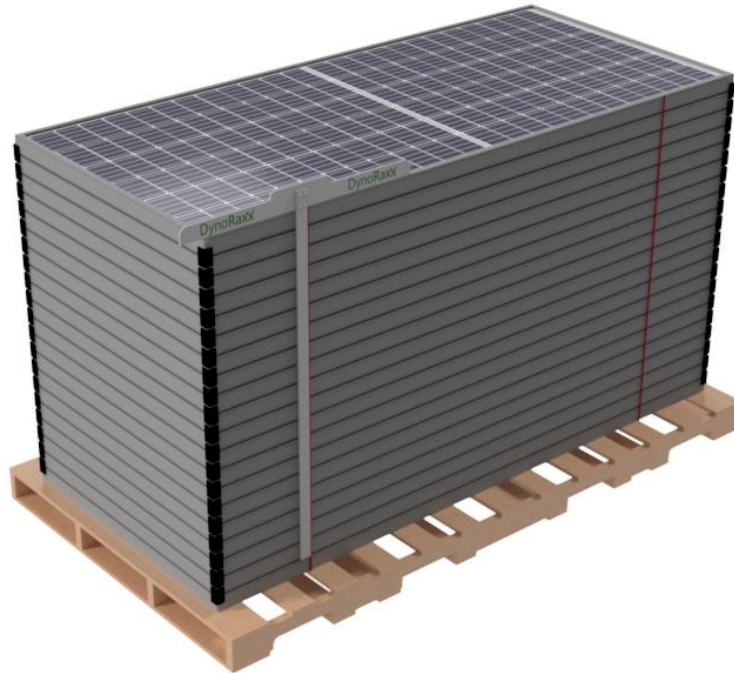

Step 4: Remove top panel and lean panel against stacked pallet.

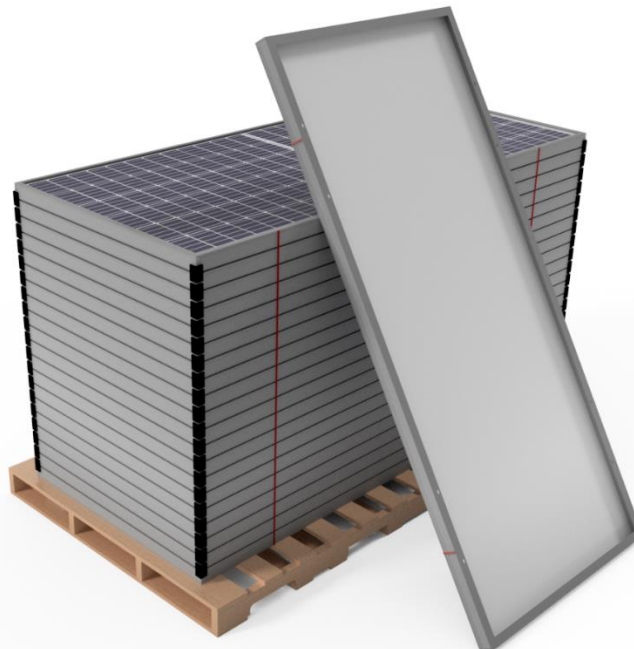

Step 5: Install DynoGrip at all 4 chalk lines by releasing lever, putting grip over the top of the bottom lip flange, and closing lever until locked in place. Ensure grip is seated properly against edge of bottom lip flange as outlined below. Lever highlighted below in Green. All portions of the DynoGrip are 304 Stainless Steel. **ONLY INSTALL 4 DYNOGRIPS PER PANEL**

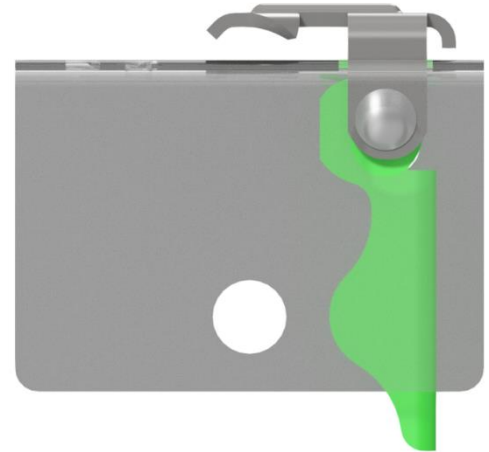
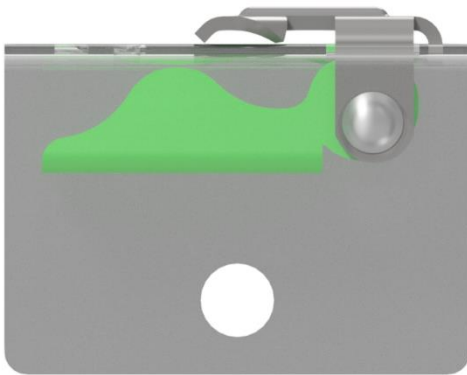

Release Lever

Ensure module frame abuts clamps “squaring” legs. This will square the clamp to the module.

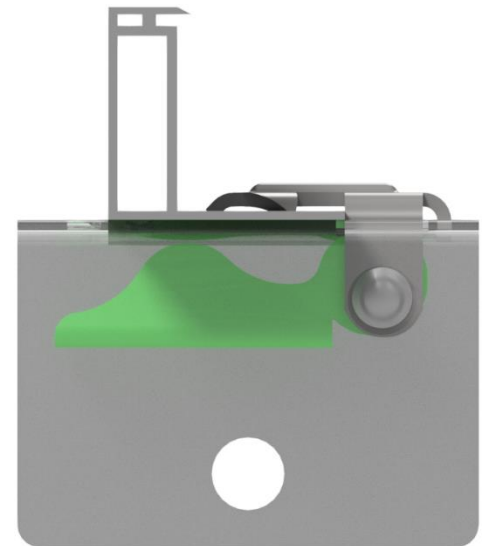
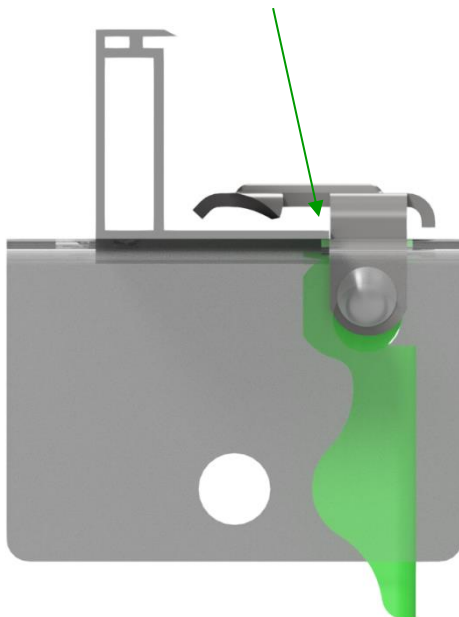

Close Clamp over module’s bottom lip flange

Step 5:

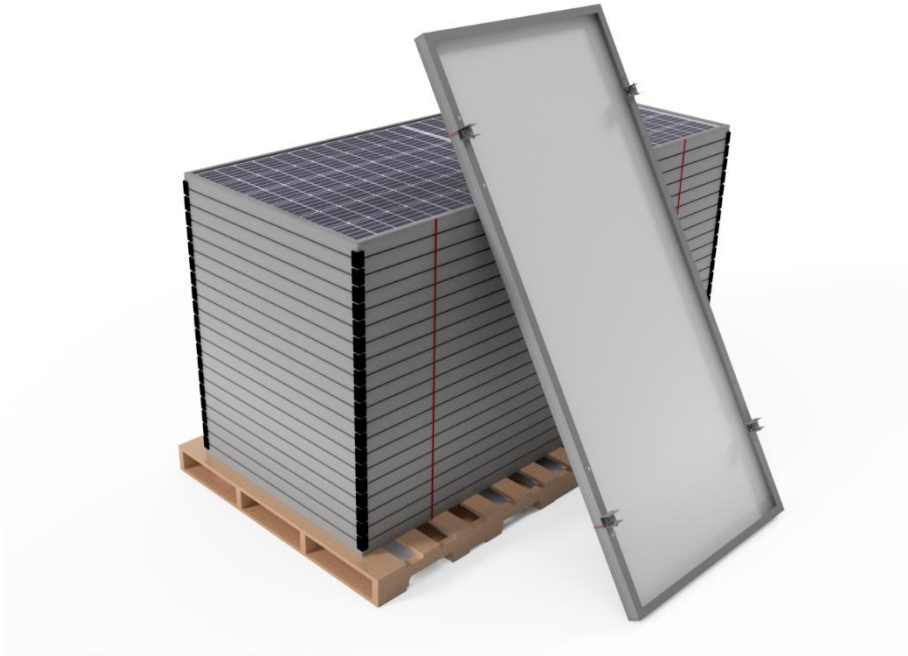

Step 6: Place the first solar panel onto the appropriate legs of each basket. The second set of baskets may need to be slid into place to fit into the DynoGrip. Insert the DynoPin into all four DynoGrips attaching the module to the baskets. Please take special care and adjust module and baskets to stay aligned with initial chalk line. **ONLY INSTALL 4 DYNOGrips PER PANEL**

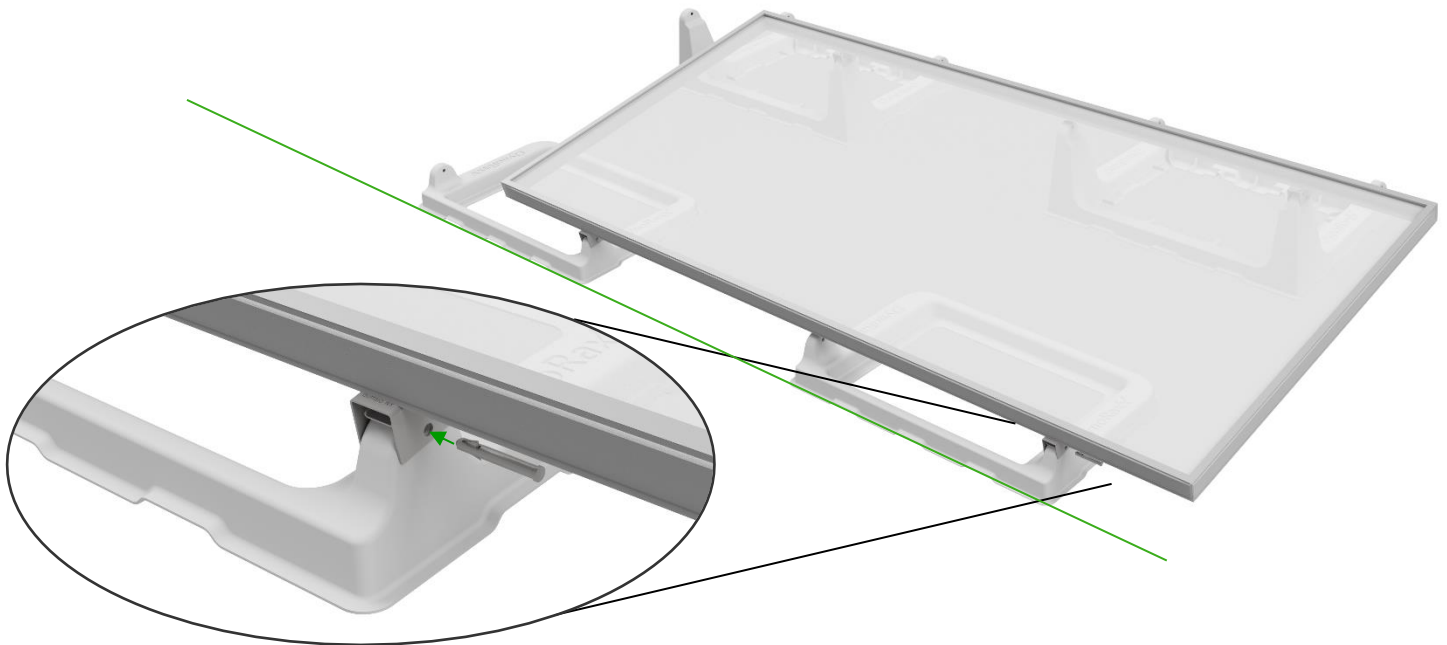

Step 7: Place the third set of Baskets approximately two feet (2') west of the second set and reposition them so that the second solar panel attaches to the legs on this set of baskets in the same fashion as step 6.

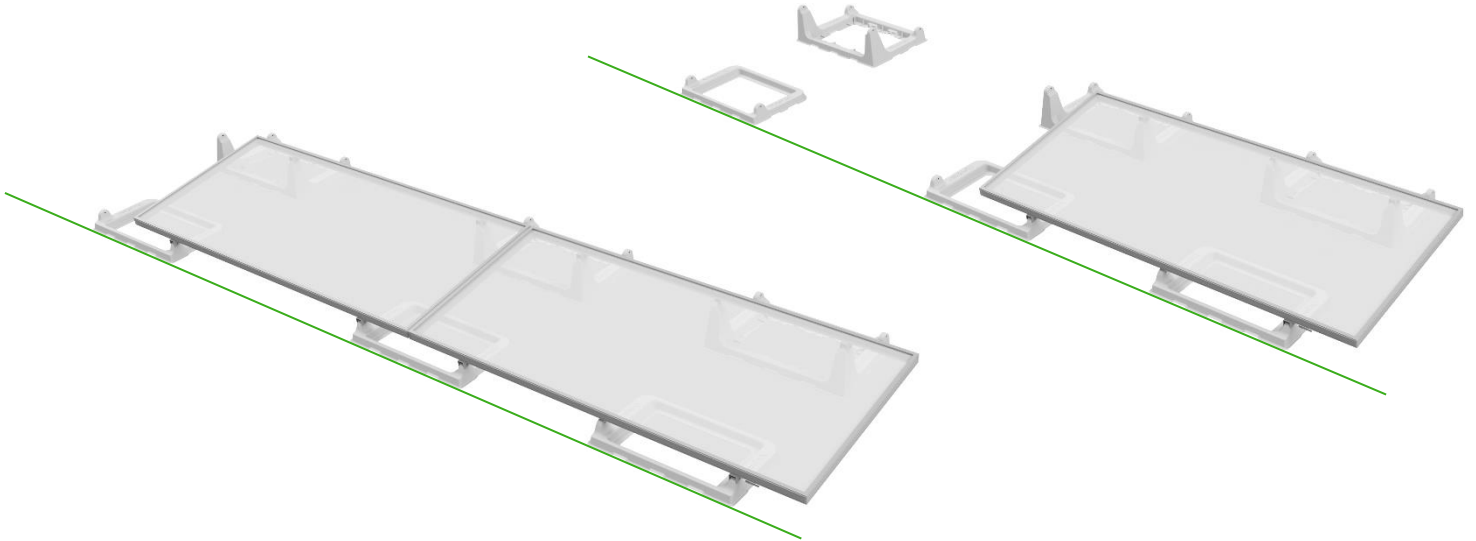

Step 8: Continue the row in the same manner as step 6. When an obstacle impedes further progression of a column, end the column by placing a four leg basket oriented with the short legs facing south.

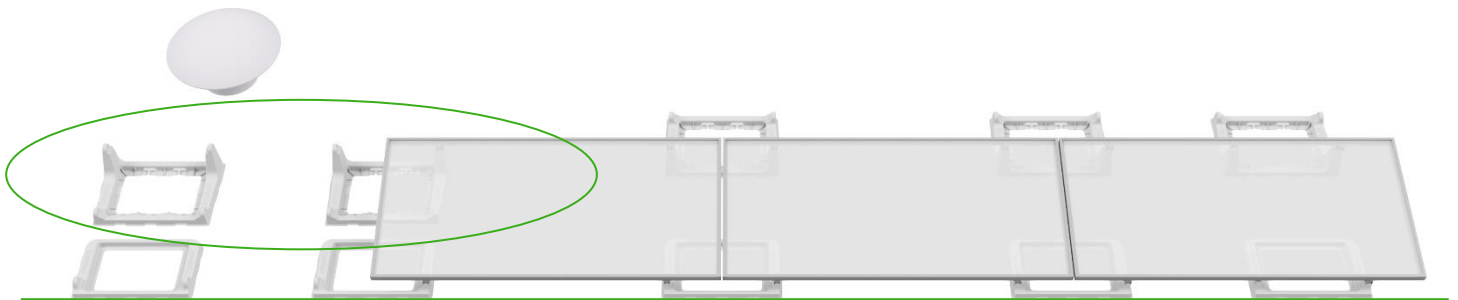

Step 1

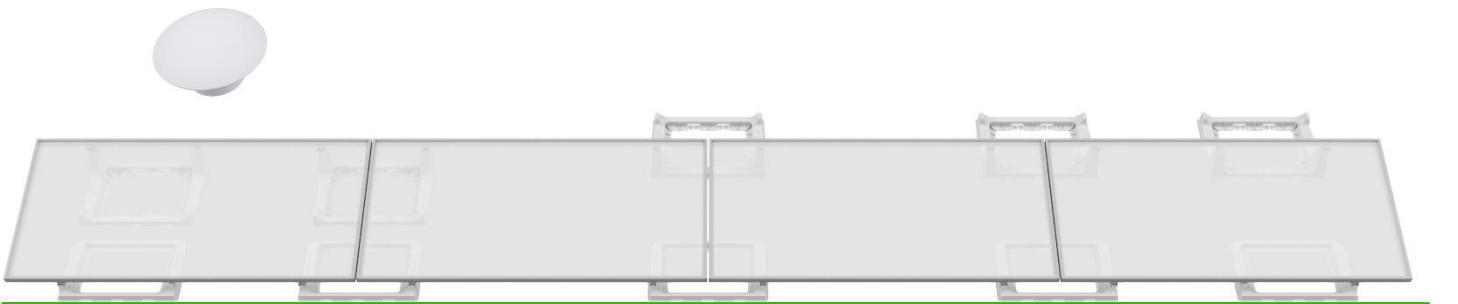

Step 2

Step 9: Once the first row of modules is in place the baskets for the remainder of the system can be laid out in the general area of where the modules will be installed. Start every additional row beginning on the eastern side of the array. Place four leg baskets positioned with the tall legs facing south.

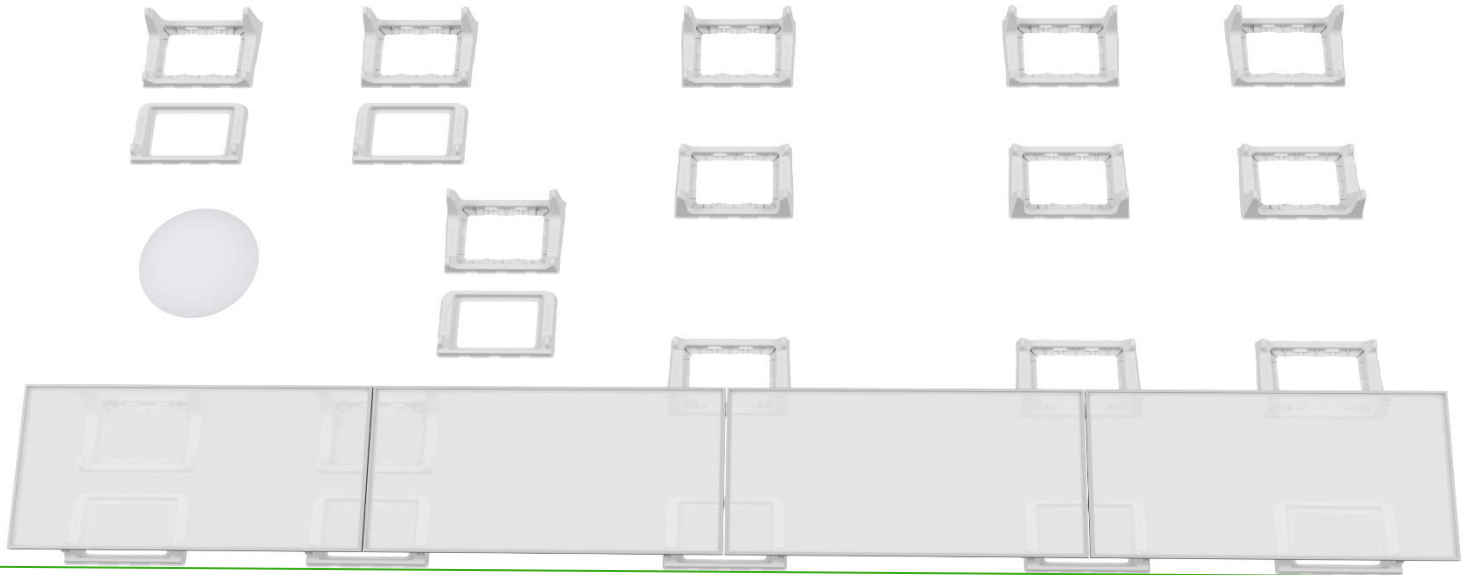

Step 10: When an obstacle impedes the progress of a row, end the row in the same manner as task eight, being. A two leg basket must be used to support the south side of this last basket set. Since this final basket set will be shifted, place a four leg basket with the short legs facing south to immediately end the column.

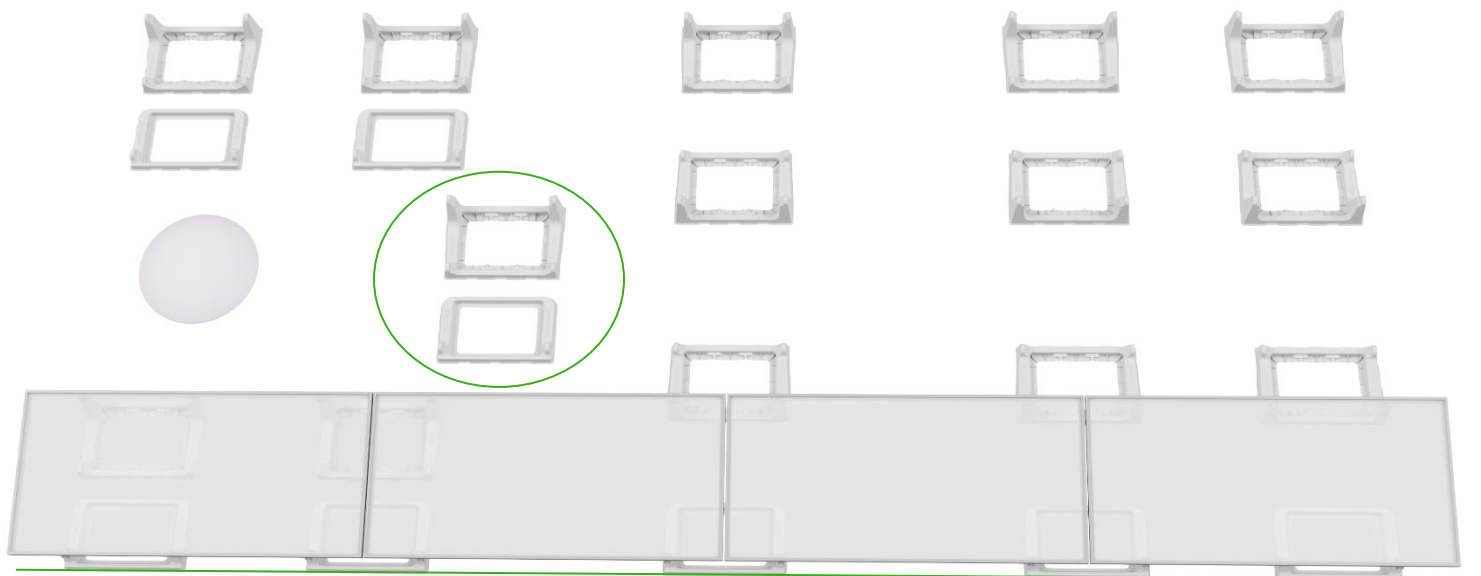

Step 11: To finish the racking for the array place four leg baskets on the north edge with the short legs facing south. Use two leg baskets in areas of column misalignment caused by the previously discussed obstacle.

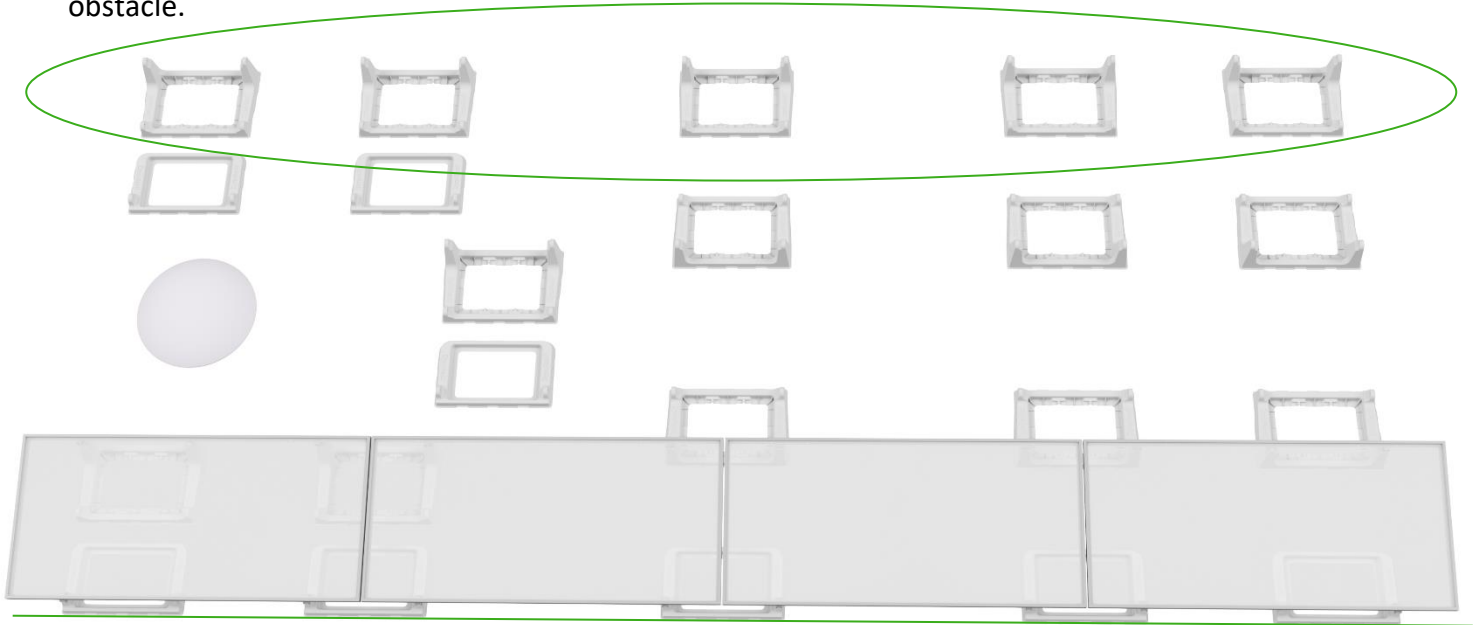

Step 12: When all baskets have been laid out. Install remaining modules on a row by row basis. Slip sheets can be added if being used once each row of modules have been completed. Ballast row and go on to next row following the same steps. Ballast blocks shall follow ASTM C1491 or C1884 where applicable. Please ensure ballast is always complete prior to leaving the jobsite.

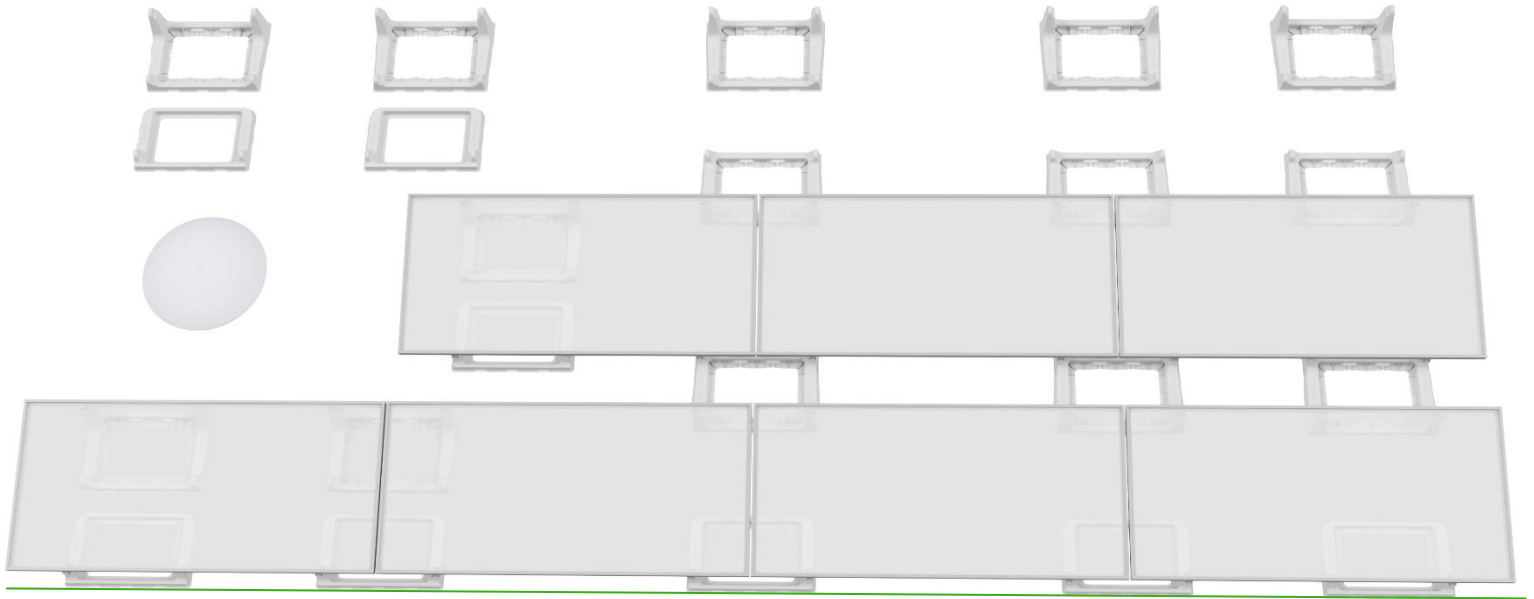

Step 1

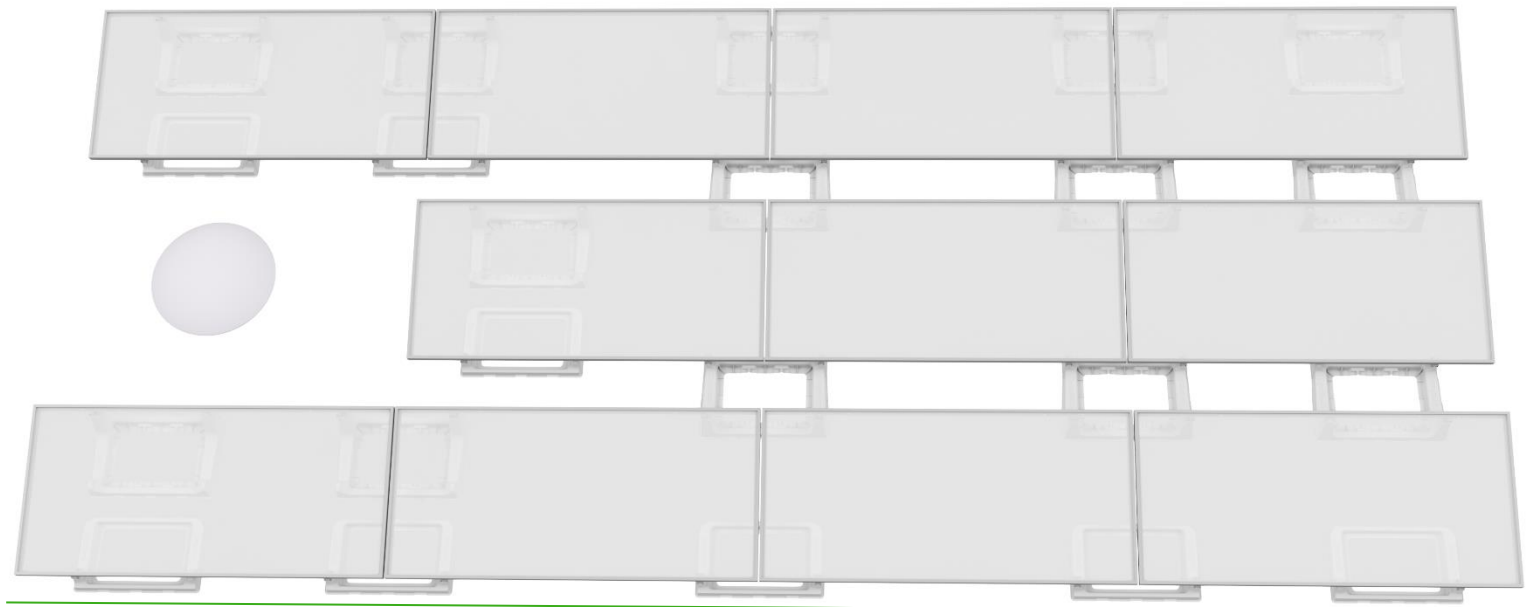

Step 2

V. Appendices

A. Ground Snow Loads – See Pages 25 and 26

(ASCE 7-05 Figure 7-1 p.84)

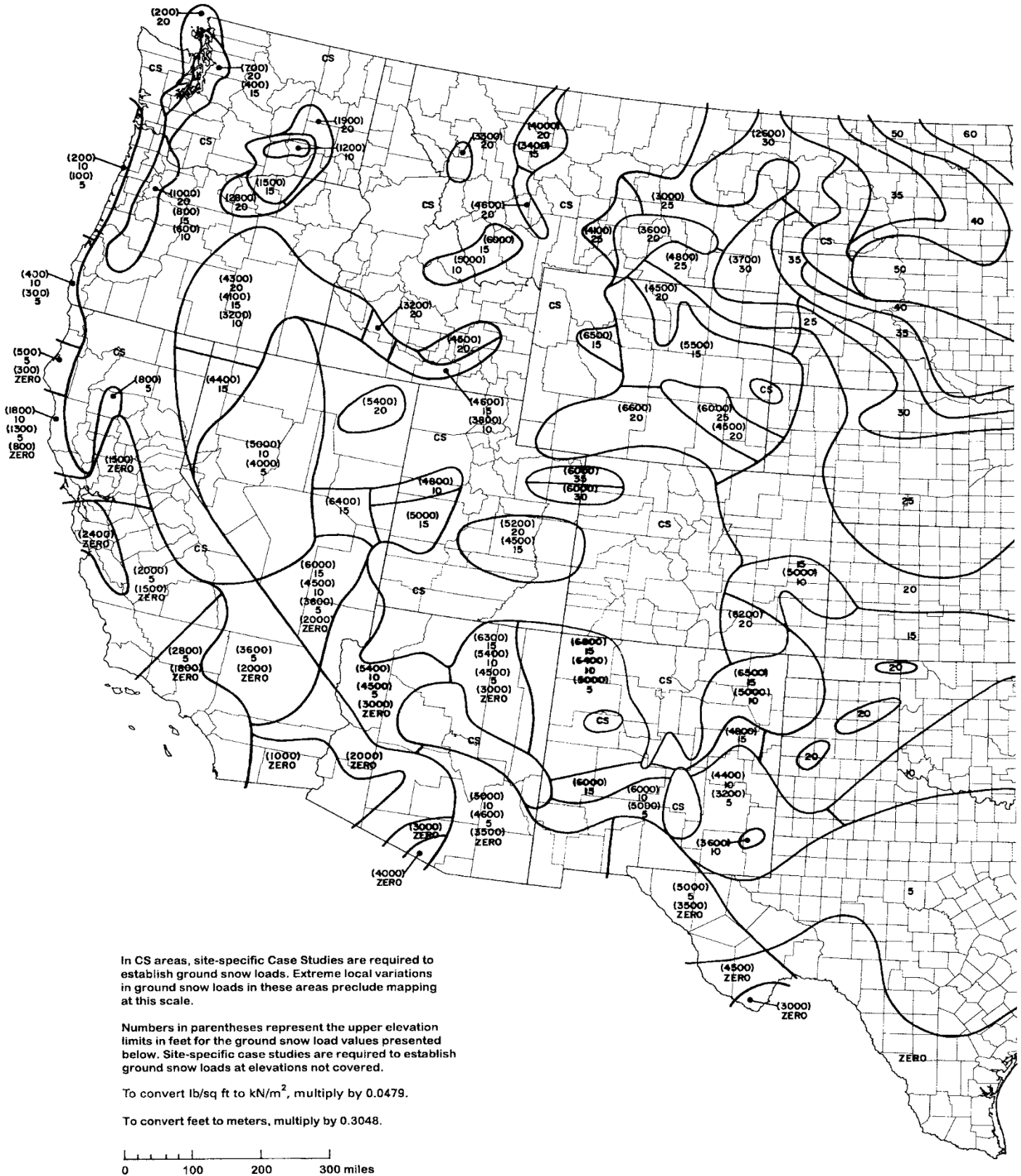

In CS areas, site-specific Case Studies are required to establish ground snow loads. Extreme local variations in ground snow loads in these areas preclude mapping at this scale.

Numbers in parentheses represent the upper elevation limits in feet for the ground snow load values presented below. Site-specific case studies are required to establish ground snow loads at elevations not covered.

To convert lb/sq ft to kN/m², multiply by 0.0479.

To convert feet to meters, multiply by 0.3048.

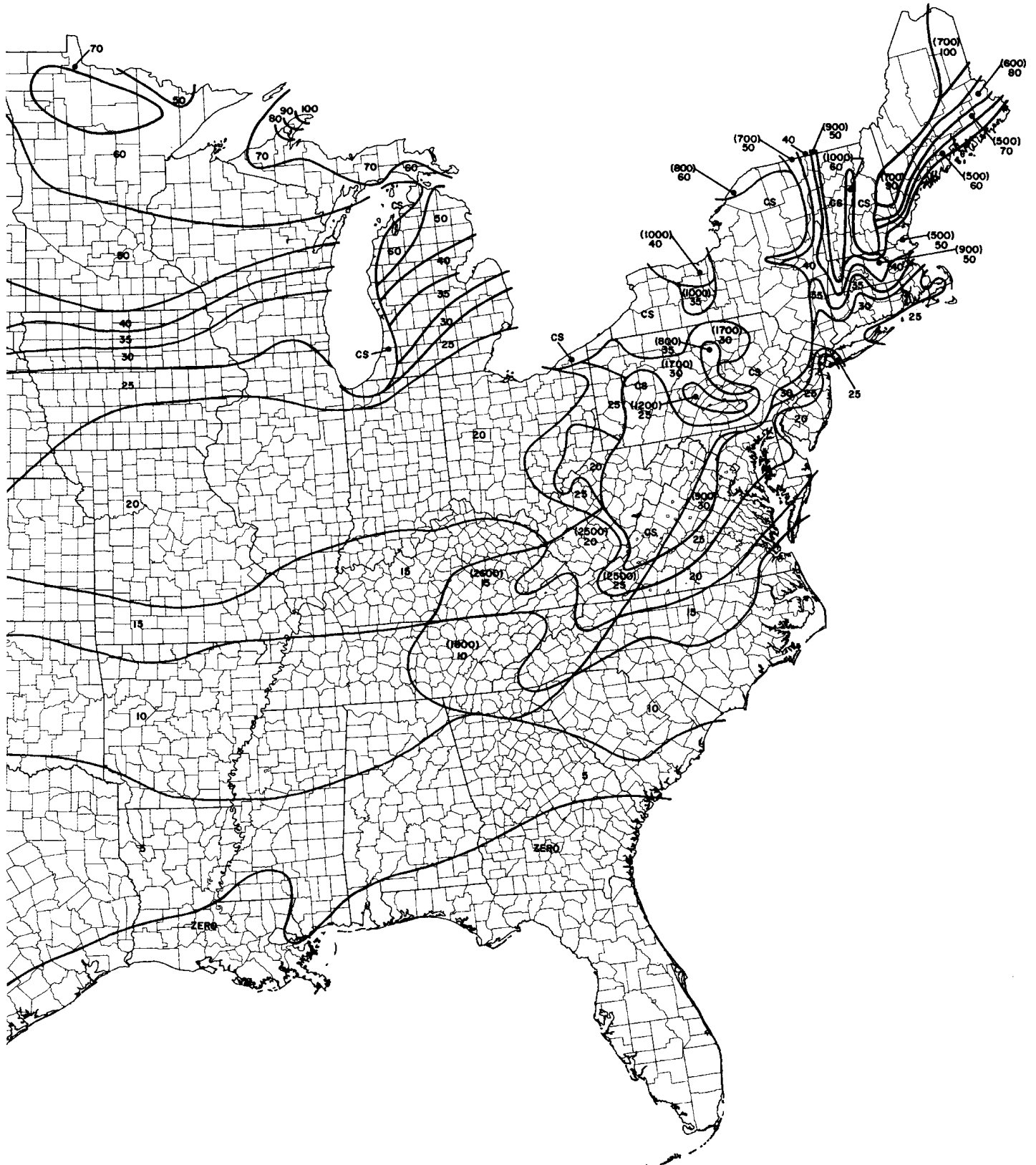

B. Applied Variables

a	Roof end zone length	n_{rS}	Number of rows with an open South edge
A_m	Area per unit module	p_c	Compressive wind load
A_{tot}	Total array area	p_s	Ground snow load
B_c	Code calculated ballast requirement	p_T	Tensile wind load
B_{drag}	Ballast requirement to overcome drag	q_h	Velocity pressure due to wind
B_{true}	Adjusted ballast requirement	S_m	Snow load force per unit module
C_{nC}	Compression pressure coefficient	Sum_1	Load force sum 1
C_{nT}	Tension pressure coefficient	Sum_2	Load force sum 2
D_m	Dead load force per unit module	Sum_3	Load force sum 3
F_0	Weight of one rail set	Sum_4	Load force sum 4
F_2	Weight of one two leg basket	V	Basic wind speed
F_4	Weight of one four leg basket	w	Building width
F_m	Weight of one module	w_{bk}	Basket width
F_{tot}	Total array weight	W_C	Compressive wind load force
F_{y-}	Negative y component of summed forces	W_{Cy}	Y component, compressive wind load force
F_{y+}	Positive y component of summed forces	W_{Cz}	Z component, compressive wind load force
F_{z-}	Negative z component of summed forces	w_m	Module width
F_{z+}	Positive z component of summed forces	W_T	Tensile wind load force
G	Gust factor	W_{Ty}	Y component, tensile wind load force
h	Building height	W_{Tz}	Z component, tensile wind load force
I	Importance factor		
K_d	Wind directionality factor		
K_{zt}	Topographic factor		
l_m	Module length		
l_0	Rail length		
n_0	Number of rail sets		
n_2	Number of two leg baskets		
n_4	Number of four leg baskets		
n_b	Number of bricks		
n_c	Number of corners not included in a South Edge		
n_m	Number of modules		
n_{mS}	Number of modules with an open South edge		
n_{mW}	Number of modules with an open West edge		

C. Applied Equations

- 1) $q_H = .00256\lambda K_{zt} V^2 I$
- 2) $p_C = q_h G C_{nT}$
- 3) $p_T = q_h G C_{nT}$
- 4) $W_T = p_T A_m$
- 5) $W_C = p_C A_m$
- 6) $W_{Ty} = W_T \sin (10)$
- 7) $W_{Tz} = W_T \cos (10)$
- 8) $W_{Cy} = W_C \sin (10)$
- 9) $W_{Cz} = W_C \cos (10)$
- 10) $S_m = p_s A_m \cos (10)$
- 11) $n_2 = n_{mS} + n_{rS} + n_c$
- 12) $n_4 = n_m + n_{mW}$
- 13) $n_0 = n_m$
- 14) $A_{tot} = \frac{1m}{144} [n_{mS} w_m \cos (10) + (n_m - n_{mS})(w_m \cos(10) + w_{bk})]$
- 15) $F_{tot} = F_m n_m + F_2 n_2 + F_4 n_4 + F_0 n_0$
- 16) $D_m = \frac{F_{tot}}{n_m}$
- 17) $Sum_1 = D_m + S_m$
- 18) $Sum_2 = D_m + W_{Cz}$
- 19) $Sum_3 = D_m + .75(S_m + W_{Cz})$
- 20) $Sum_4 = .6D_m + W_{Tz}$
- 21) $\frac{1}{4} \sqrt{F_{zmax}^2 + F_{ymax}^2} < 830$
- 22) $F_{fr} = .6D_m \mu$
- 23) $B_{drag} = \frac{1}{.4} (W_{Ty} - F_{fr})$
- 24) $B_c = B_{drag} + F_{zneg}$
- 25) $B_{true} = (.473) 1.15 B_c$
- 26) $n_b = \frac{B_{true}}{34}$

D. DynoRaxx DYNOGRIP EVOLUTION FR System Orientation

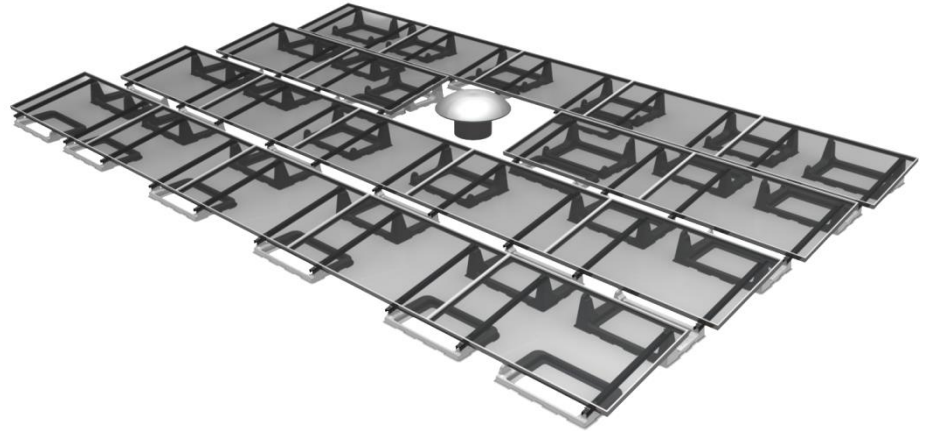
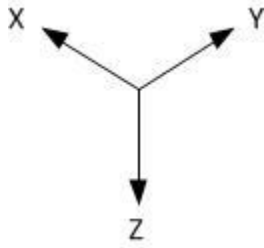

*The x axis is referred to as side to side motion while the y axis is back and forth. The Z axis would be described as up and down.

E. DynoRaxx Limited Warranty

A. MATERIAL AND WORKMANSHIP WARRANTY

1. DynoRaxx, Inc., ("DynoRaxx") warrants to the original registered purchaser ("Purchaser") of the [DynoRaxx® flat-roof PV ballasted racking systems/DynoRaxx® pitched roof PV mounting system] and related DynoRaxx branded accessories ("Product") for installation at the original installation site when shipped in its original container that the Product shall be free from structural defects in material and workmanship that render the Product inoperable for its intended purpose.
2. DynoRaxx agrees that for a period of ten (10) years from the date of purchase by the first consumer purchaser, that DynoRaxx will, at its sole discretion, either (i) repair the defect, (ii) replace the defective Product, or (iii) compensate Purchaser the purchase price of product times full years remaining on Material and Workmanship Warranty divided by 10 years.
3. This Limited Warranty shall be effective on January 1, 2012, the "Effective Date."
4. The compensation, replacement, substitution, or repair as outlined above shall completely satisfy and discharge all of DynoRaxx's liability with respect to the Limited Warranty.

B. WARRANTY EXCLUSIONS AND LIMITATIONS

1. The Limited Warranty does not cover superficial defects such as surfaces that are scratched, chipped, oxidized, corroded or broken unless such superficial defects cause the Product to become inoperable or malfunction.
2. The Limited Warranty shall be VOID if Product is or was (a) exposed to corrosive materials or chemicals that can weaken or contribute to Product degradation or malfunction; (b) used in marine or saltwater environments; (c) used under abnormal environmental conditions including, without limitation, conditions where the Product is exposed to or in contact with water, salt, smoke, oils or fuel; (d) used on mobile units, including, without limitation, mobile homes, automobiles, boats, and other vehicles; (e) subject to abuse or misuse; or (f) disassembled and transported from its original location.
3. The Limited Warranty does not cover damage to the Product that occurs during shipment, storage, or installation. In a case where a manufacturing defect is visible at the time materials are delivered, DynoRaxx should be informed immediately upon delivery and written claim must be made within one-month after the date of delivery, and always prior to the installation of the visually defective product.
4. The Limited Warranty shall be VOID if (a) installation of the Product did not follow DynoRaxx's written installation instructions, (b) if the Product has been altered, modified, reconfigured or repaired in a manner not previously authorized by DynoRaxx IN WRITING, (d) if the Product is not installed for a purpose for which the Product was intended.

5. The Limited Warranty will be VOID if in DynoRaxx's sole judgment, a Product has been damaged or subject to misuse, negligent installation, maintenance or use, accident, abuse, alteration, vandalism, theft, excessive heat, fire, exposure to improper voltage, power surge, act of God (including lightning, floods, pests, earthquakes, extraordinary weather conditions, typhoons, hurricanes or volcanic eruptions), acid rain, corrosive environment, and actions of third parties (including acts of war or terrorist acts).
6. The Limited Warranty shall not apply if the label or serial number has been altered, removed, defaced, or is otherwise illegible or unrecognizable.

C. COVERAGE SCOPE

1. Purchaser (and not DynoRaxx) shall bear all cost relating to the return of Product to DynoRaxx including risk of loss, theft or damage during shipping. Purchaser at its own discretion may obtain insurance for shipping the Product back to DynoRaxx.
2. DynoRaxx shall not be liable under the Limited Warranty for any labor costs or for the repair, replacement or supplementation of a defective Product or for any material or parts other than defective Products that may be required to complete the repair, replacement or supplementation under any circumstances. To the extent that DynoRaxx, or its agents, are performing a repair, replacement or supplementation of a defective Product, Purchaser shall be responsible to pay DynoRaxx or its agents for all such labor costs and material or parts other than defective Products.
3. Without limiting the foregoing, DynoRaxx shall not be liable under the Limited Warranty for damage to persons or property or other loss or injury resulting from defect in the Product or from improper installation, maintenance or use. DynoRaxx will not under any circumstances be liable for any indirect, special, incidental or consequential damages of any nature, whether based on contract, tort or other legal theory including, without limitation, business interruption costs, removal and/or reinstallation costs, re-procurement costs, loss of profit or revenue, loss of data, promotional or manufacturing expenses, overhead charges, injury to business reputation or loss of customers, even if DynoRaxx has been advised of the possibility of such damages.
4. Manufacturers of related items used with Product including third party manufactured solar panels, inverters, batteries, wiring, mounts, racking systems, flashings, electrical systems, parts, supplies, and plumbing systems, if any, are not covered by this Warranty. This Warranty shall not cover replaceable parts such as fuses or breakers.

D. NO OTHER WARRANTIES

THIS LIMITED WARRANTY IS EXPRESSLY IN LIEU OF AND EXCLUDES ALL OTHER EXPRESS OR IMPLIED WARRANTIES, INCLUDING, BUT NOT LIMITED TO, THE WARRANTIES OF MERCHANTABILITY AND FITNESS FOR A PARTICULAR PURPOSE AND ALL OTHER OBLIGATIONS OR LIABILITIES ON THE PART OF DYNORAXX, UNLESS SUCH OTHER WARRANTIES, OBLIGATIONS OR LIABILITIES ARE EXPRESSLY AGREED TO IN WRITING BY DYNORAXX.

E. CLAIM FILING INFORMATION

1. To file a claim under the Limited Warranty, Purchaser needs to present (1) name and contact information for Purchaser, (2) identity of distributor from whom the Product was purchased, (3) identification of all Product that fails to comply with the Limited Warranty including the serial number for each Product, (4) adequate documentation that the Product fails to comply with the terms of the Limited Warranty explicitly set forth above, and (5) adequate written proof of the date of delivery of the Product including a dated sales contract, fully executed purchase order, bill of lading, courier tracking information or other reasonable proof of the date of delivery of the Product. Please send the documentation described above to:

DYNORAXX WARRANTY CLAIMS

DynoRaxx, Inc.
6500 Sheridan Drive, Suite 120
Buffalo, NY 14221
warranty@dynoraxx.com

2. After receiving a claim, DynoRaxx will consider the documentation and have a reasonable period of time to investigate the merit of the claim under the Limited Warranty ("Claim").

3. If in the sole discretion of DynoRaxx, the investigation of the Claim requires further physical inspection by DynoRaxx of some or all of the Product that are the subject of the Claim ("Claim Related Product"), then DynoRaxx (in its sole discretion) may issue a return material authorization (RMA) with detailed instruction and authorization for Purchaser to return a specified Product ("Return Authorized Product") to DynoRaxx.

4. DynoRaxx will not accept any Product other than a Return Authorized Product. Purchaser shall bear the cost of disassembling, packaging, shipping and, if applicable, insuring a Return Authorized Product to DynoRaxx.

5. Should DynoRaxx determine that the Limited Warranty has been breached, DynoRaxx has the option (in its sole discretion) to satisfy its obligations under this Limited Warranty with Product repair,

replacement or supplementation and will issue detailed instructions which may include an RMA or a visit to the installation site. Failure to comply with an RMA or provide reasonable access during normal business hours to installation site within a reasonable period of time shall invalidate the Limited Warranty. Any Product replaced under this Limited Warranty shall become the sole property of DynoRaxx.

6. DynoRaxx may supply used or repaired Products as replacement. DynoRaxx has the right to deliver a replacement Product of a different type than the replaced Product if DynoRaxx has discontinued producing the replaced Product at the time of the claim.

7. This Limited Warranty shall be granted and construed in accordance with the laws of New York, without regard to the jurisdiction’s conflict of law provisions. Purchaser agrees that any dispute over this Limited Warranty shall be exclusively resolved in the courts of Erie County, New York State.

8. If any provision of this Limited Warranty is held unenforceable or illegal by a court or other body of competent jurisdiction then such provision shall be modified to the minimum extent required so that the remainder of this Limited Warranty will continue in full force and effect.

9. This Limited Warranty is subject to change or termination by DynoRaxx without prior notice by publication on solarliberty.com and shall be applicable to all Product sold after the date of publication of such notice of revision or termination (“Termination Date”).

F. PARTS AND COMPONENTS COVERED

Product covered under this revision of the Limited Warranty shall be sold after the Effective Date and before the Termination Date for the following Components:

DynoRaxx 2 Leg Baskets

DynoRaxx 4 Leg Baskets

DynoGrip

DynoPin Locking Pins

DynoFeather 2 Leg

DynoFeather 4 Leg

DynoRaxx PR Clamp

F. Standard Module Mounting Detail

